

May 2002

Dear ZODIAC builder:

Over the years, several Zodiacs have lost their canopies in flight due to improper latching or unintentional opening of the latch hooks.

While I like the simple latch design that allows opening the canopy from either side, the latch system can quite easily be opened in flight, whether from improper closing or from a shoulder harness inadvertently looped around a latch hook.

Check that the canopy hooks clearly extend past the canopy frame when latched closed. Longer hooks minimize unintentional opening. The following drawing (6E2-1) shows a canopy latch with a longer hook. The easiest way to install the longer hooks is to bolt new ones to the existing canopy hooks. These hooks are available from Zenith Aircraft Company as replacements to those supplied in the kit. To order new hooks please contact Zenith Aircraft Company.

Some builders have also added additional latches or safety locks to prevent accidental opening in flight. A simple latch can be very effective in accomplishing this.

Also, make sure that the following is included in your aircraft operating handbook / checklist:

- Check that the canopy hooks on both sides are securely latched, and unobstructed, before and during flight.
- Brief your passenger on how the system works, and the importance of keeping the latch securely closed during flight.

As the builder / owner / mechanic of your aircraft, it is your responsibility that the aircraft is operated safely. Please take the time to make sure that your canopy system is not prone to accidental opening in flight.

If you have sold your kit or aircraft, please forward this letter to the new owner. Please contact me if you have any questions regarding this, or contact Zenith Aircraft Company.

Regards,

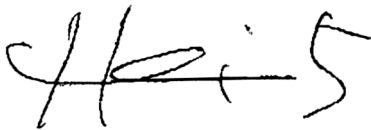

Chris Heintz,
Designer.

Enclosure: Drawing 6E2-1.

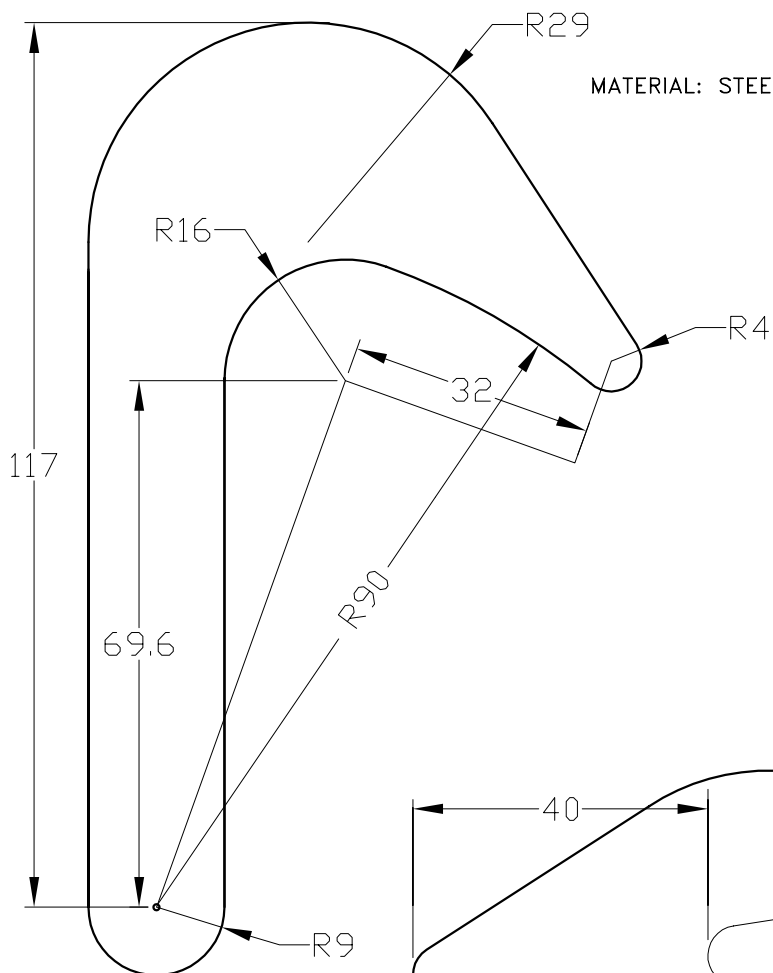

MATERIAL: STEEL $t=1/8"$ or 4130N $t=.125"$

LONGER CANOPY HOOK

THE LONGER HOOK WILL MINIMIZE UNINTENTIONAL OPENING

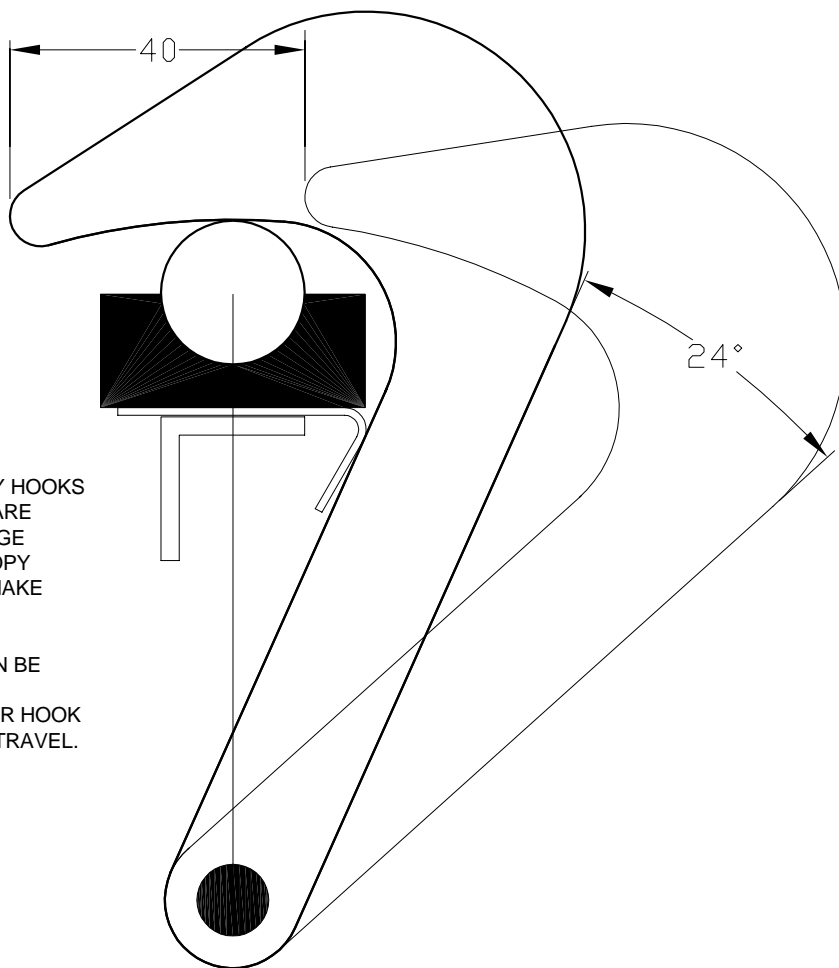

CHECK THAT THE END OF THE CANOPY HOOKS EXTEND THROUGH THE CANOPY AND ARE VISIBLE FROM OUTSIDE THE FUSELAGE (THROUGH CUTOUT SLOT IN THE CANOPY BUBBLE AND OUTSIDE FLASHING TO MAKE ROOM FOR THE HOOK).

IF NECESSARY THE LONGER HOOK CAN BE BOLTED WITH 2 BOLTS AN3-4A TO THE EXISTING HOOK. TO OPEN, THE LONGER HOOK REQUIRES APPROXIMATELY 40MM OF TRAVEL.

DESCRIPTION

ZODIAC CH 600, CH601HD & CH601HDS CANOPY HOOK

6E2-1