

FINISHED FORM

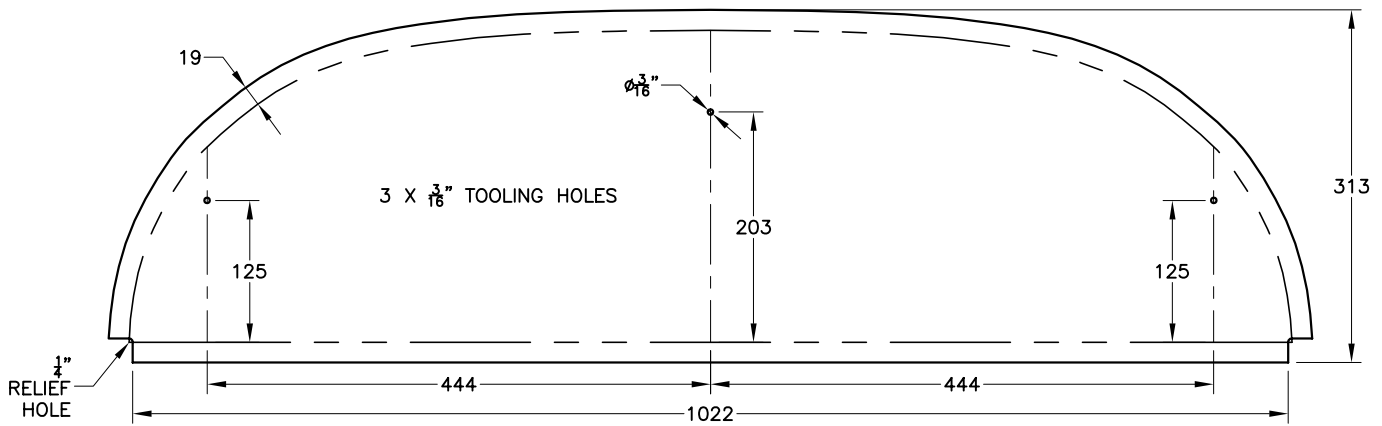

BLANK LAYOUT

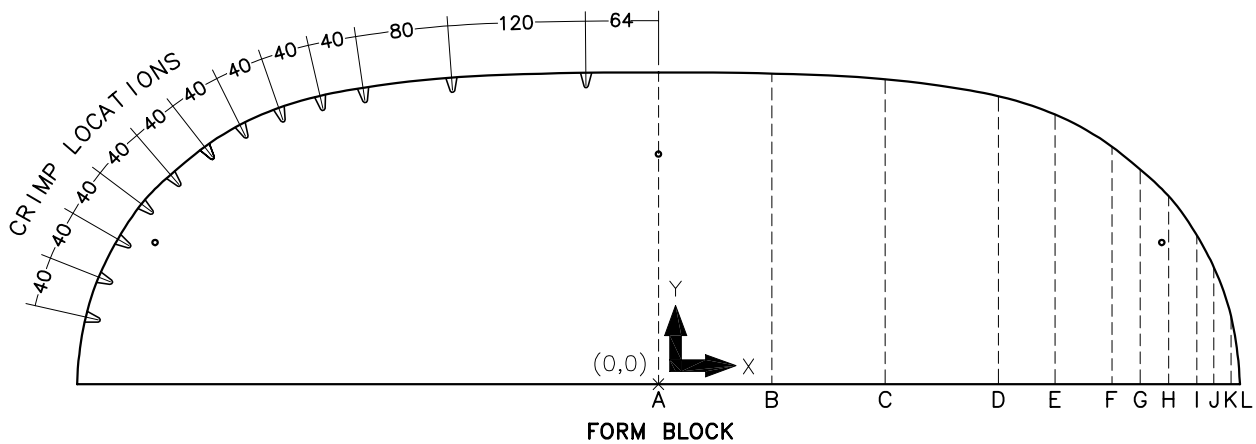

FORM BLOCK

FORMING BLOCK COORDINATES												
	A	B	C	D	E	F	G	H	I	J	K	L
X	0.0	100.0	200.0	300.0	350.0	400.0	425.0	450.0	475.0	490.0	505.0	513.0
Y	275.0	274.0	269.5	255.0	238.5	212.0	194.0	170.0	139.5	113.0	70.0	0.0

STOL
CH 801

ORIGINAL INFO
MJM 02/27/02
REVISION INFO

DESCRIPTION

INSTRUMENT PANEL

MATERIAL 6061-T6 t=.032" QTY 1

PART NO.

8F1-2

COPYRIGHT © 2002 ZENITH AIRCRAFT CO. WWW.ZENITHAIR.COM