

WING PICK UP TEMPLATE
MADE WITH A 2 X 4 BOARD

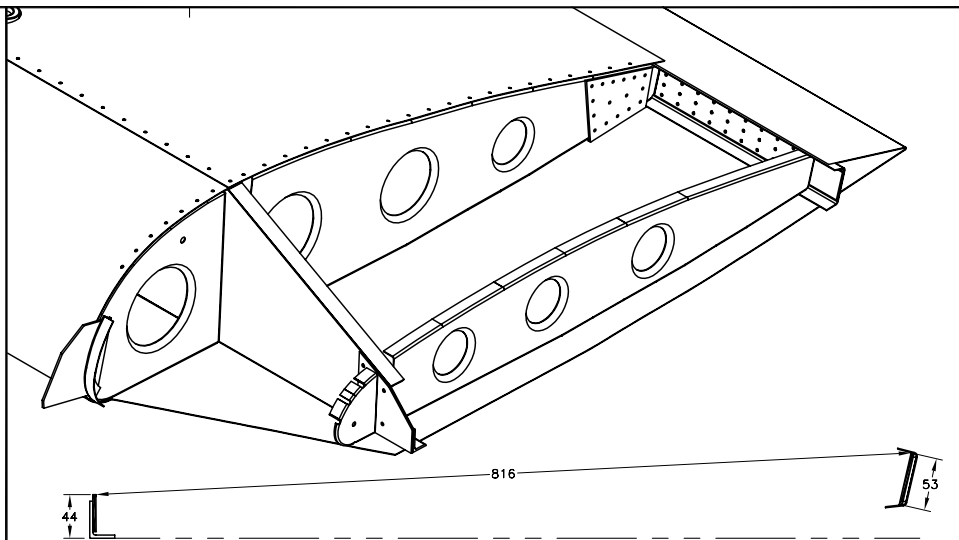

1. CLAMP ONE PIECE OF 1/8" MATERIAL AT 44mm FROM THE BOTTOM OF THE BOTTOM MAIN SPAR ANGLE. ALSO CLAMP ONE PIECE OF 1/8" MATERIAL ON THE INSIDE OF THE REAR SPAR AS FAR UP AS POSSIBLE.
2. MEASURE THE DISTANCE TO AND FROM EACH 1/8" PIECE ON THE TOP INSIDE EDGE. THIS DISTANCE SETS THE INSIDE DISTANCE BETWEEN 8F5-1 WING ATTACHMENT BRACKET AND 8F18-1 CABIN FRAME'S WING ATTACHMENT (WING PICK UP TEMPLATE).

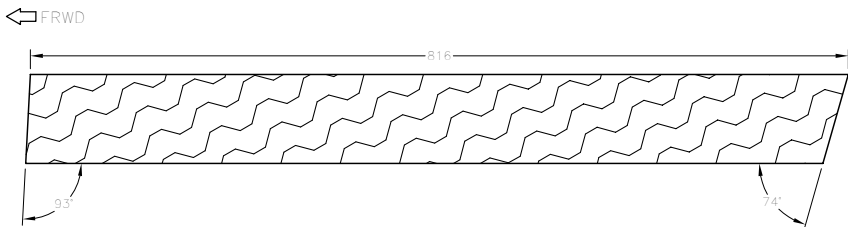
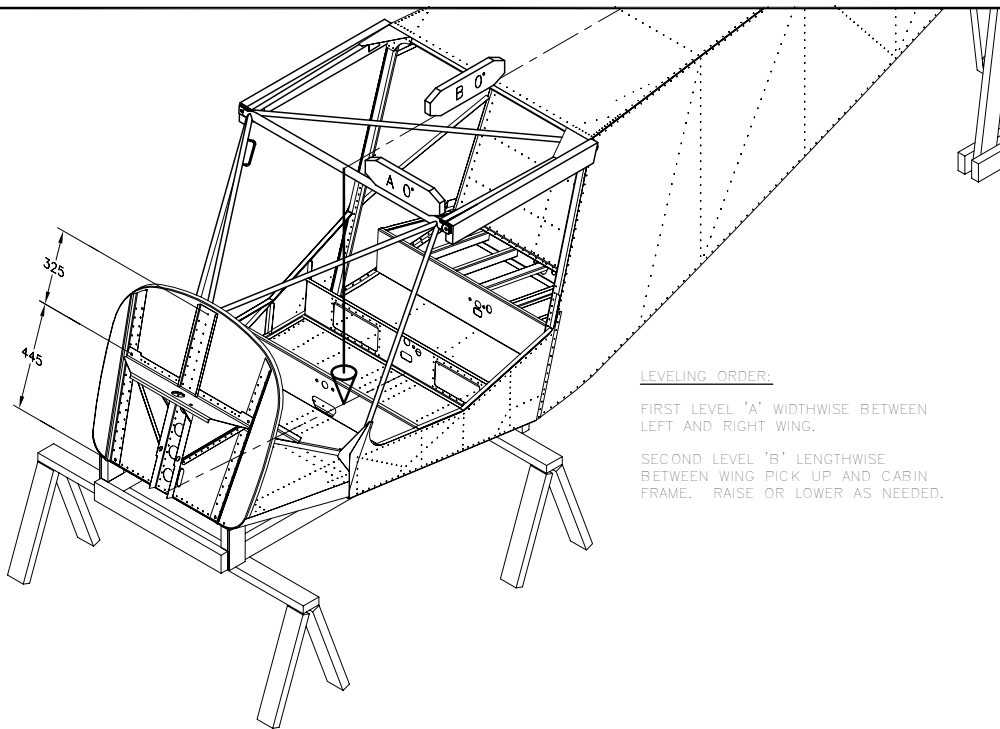

LEVELING ORDER:

FIRST LEVEL 'A' WIDTHWISE BETWEEN LEFT AND RIGHT WING.

SECOND LEVEL 'B' LENGTHWISE BETWEEN WING PICK UP AND CABIN FRAME. RAISE OR LOWER AS NEEDED.

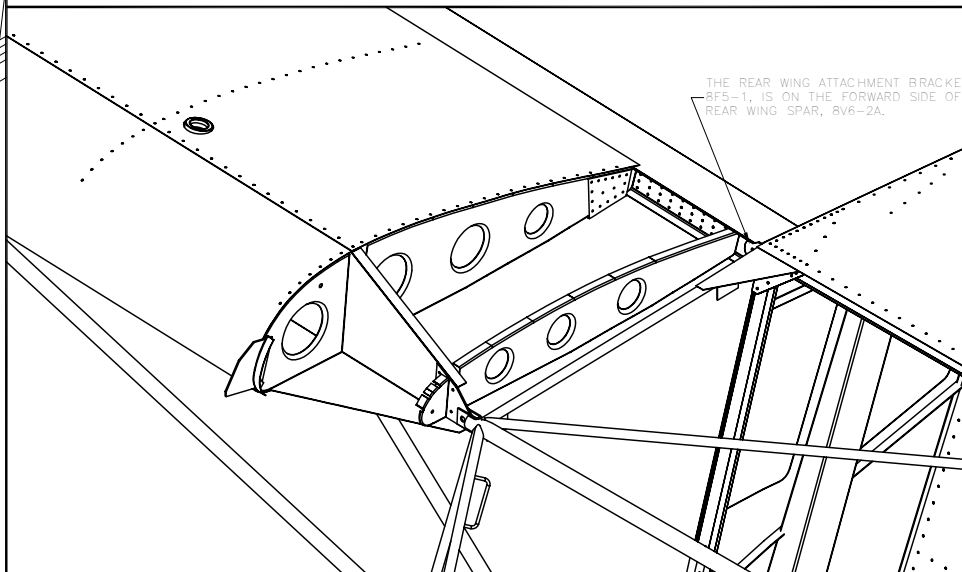

THE REAR WING ATTACHMENT BRACKET, 8F5-1, IS ON THE FORWARD SIDE OF REAR WING SPAR, 8V6-2A.

STOL CH 801	ORIGINAL INFO MJM 04/01/02 REVISION INFO	DESCRIPTION	ASSY NO.
		FUSELAGE: CABIN CABIN FRAME INSTALLATION	8FC-3
COPYRIGHT © 2002 ZENITH AIRCRAFT CO. WWW.ZENITHAIR.COM			