

STOL CH 750

LIGHT SPORT UTILITY AIRPLANE

**SPORT
READY
PILOT***

**"Simple to Build,
Fun to Fly"**

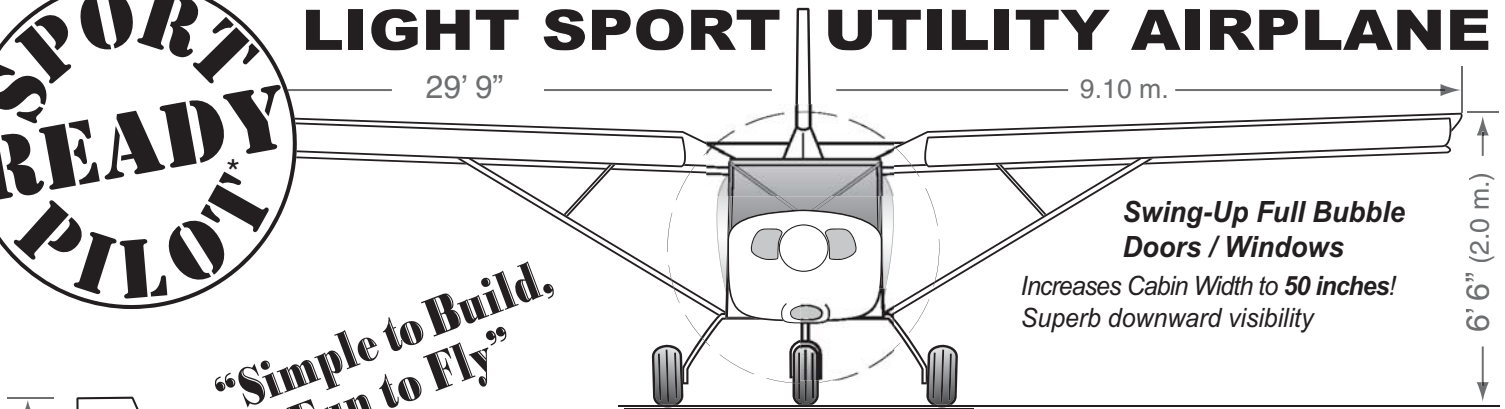

**Swing-Up Full Bubble
Doors / Windows**

*Increases Cabin Width to 50 inches!
Superb downward visibility*

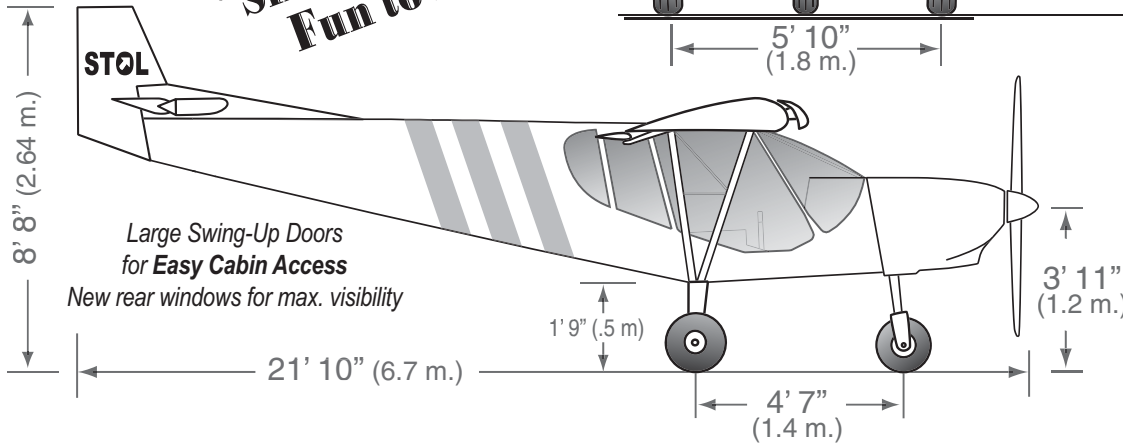

Based on the very popular STOL CH 701 design from Chris Heintz that was first introduced more than twenty years ago, the all new STOL CH 750 design incorporates the 701's amazing short-field capabilities, while maximizing cabin size and load carrying capability allowed under the FAA's new Sport Pilot / Light Sport Aircraft category.

**Two Seats
STOL Performance!
Light Sport Utility**

Build your own from:
- Plans (blueprints),
- component kits,
- Complete Kits

"Modern, Roomy Robust"

- KITPLANES Magazine (2/2009)

- Amazing short take-off and landing (STOL) performance
- Surprisingly efficient cruise
- Huge cabin, side-by-side seating
- Large Baggage Area
- Spectacular visibility
- Great bushplane capabilities, simplicity of a tricycle gear.

All-new kit made with state-of the art CNC equipment

- ✦ The kit includes precision CNC cut and drilled parts.
- ✦ Extensive use of "match-hole" assemblies.
- ✦ Factory-built and riveted main wing spars.
- ✦ CAD blueprints and detailed photo assembly manuals.
- ✦ Manufactured and supported in the USA.

Engine Choices:

- Jabiru 3300,
- Continental O-200,
- Rotax 912 ULS and 914,
- auto conversions,
and more...

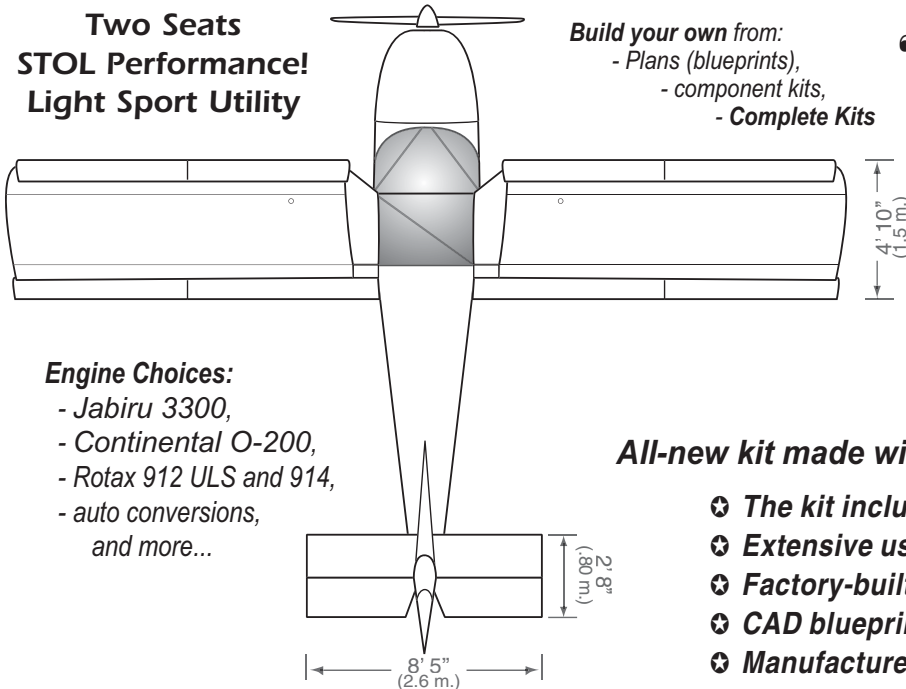

Sport Pilot Ready: *Subject to meeting FAA rules as constructed by the builder. Zenith Aircraft Company cannot guarantee that the kit aircraft, as constructed by the builder, will meet the definition of a Light-Sport Aircraft. Larger and heavier engines and other installed equipment will limit the useful load of the aircraft, and may disqualify the aircraft from meeting the defined category limits. Specification and performance figures are based on factory prototype test results, and are subject to change and revision without notice. Equipment and availability subject to change.

ZENITH AIRCRAFT CO.

PO Box 650, Mexico Memorial Airport,
Mexico, Missouri 65265-0650 USA
TEL: 573-581-9000 FAX: 573-581-0011



Information Manual: \$15.00
Demo Video (DVD or VHS): \$20.00

Visit us online for complete details
zenithair.com

STOL CH 750: PRICE LIST

STOL CH 750 PLANS & PHOTO ASSEMBLY GUIDES

Detailed blueprints of the complete airframe and components (CAD drawings), supplied with a serial number: All you need to 'scratch-build' your own STOL CH 750 Light Sport Utility Aircraft.

Comprehensive **Photo Assembly Guides** (manuals) are included on CD-ROM.

Plans and manual are included with the complete airframe kit. Add \$15.00 for overseas Air Mail shipping.

STOL CH 750 Drawings & Manuals	\$ 495.00
---	------------------

STOL CH 750 COMPLETE KIT: Airframe Kit + Finishing Kit

The STOL CH 750 Airframe Kit comes with all kit parts to build the airframe: The kit includes the factory riveted wing spars, pre-formed sheet-metal parts (ribs, skins, etc.), factory-welded parts, standard fuel system (wing tanks), controls, and hardware required for the assembly of the airframe. Most skins and parts are supplied CNC cut and drilled! The airframe kit includes the Drawings and Manuals.

The STOL CH 750 Finishing Kit includes the items to complete the aircraft, including the gear and wheels with hydraulic disk brakes, the formed plexiglass windshield, formed bubble doors, seat belts, wing struts, electric flap and elevator trim motors, various hardware, and more.

Not included: firewall-forward engine and instruments packages, paint, and upholstery. Crating and shipping charges are extra.

STOL CH 750 Airframe Kit	\$ 14,990.00
---------------------------------	---------------------

STOL CH 750 Finishing Kit	\$ 4,490.00
----------------------------------	--------------------

COMPONENT KITS

You may choose to purchase sections of the complete kit to 'buy-as-you-build' (instead of ordering the complete airframe kit as a single package). The Plans and Manuals must be purchased separately. Individual parts and components are also available.

COMPONENT KITS	STOL CH 750
WINGS KIT	\$ 4,975.00
FLAPERONS & SLATS KIT	\$ 1,895.00
TAIL KIT	\$ 1,475.00
FUSELAGE KIT	\$ 4,250.00
CONTROLS KIT	\$ 1,525.00
FUEL SYSTEM KIT (Wing tanks, order with the Wings Kit)	\$ 995.00
<hr/>	
SAVE ON COMPLETE AIRFRAME KIT (Includes Drawings & Manuals)	\$ 14,990.00
FINISHING KIT (see above)	\$ 4,490.00

KIT OPTIONS AND FIREWALL-FORWARD ENGINE PACKAGES

Thanks to the long list of STANDARD equipment included in the airframe and finishing kits, there are few additional options needed or recommended. Most options are available as a retrofit. Please visit www.zenithair.com for a list of available options, including nav / strobe lights kit, extended fuel (long-range) tanks, etc.

Zenith Aircraft Co. plans on making available a number of complete firewall-forward engine packages for the STOL CH 750, including: Continental O-200 / Mattituck TMX-0-200, Jabiru 3300, Rotax 912S / 914, and the Corvair auto conversion. Zenith also plans to offer complete instrument panels, with EFIS and avionics, for the STOL CH 750.

See www.zenithair.com for the latest price information and updates. Prices in U.S. funds. All shipping and freight charges collect (F.O.B. Factory). All prices, equipment and availability subject to change without prior notice.

750-price1.ai 8-2008

PRICE LIST: TOOLS & CRATING

COMPLETE TOOL KIT – OPTIONAL

The complete tool kit includes all the basic tools you'll need to get started on building your own kit aircraft. The tool kit includes:

- ✦ Sioux Air Drill, model DR1412, 3600 rpm
- ✦ Pneumatic Riveter with Custom Machined Heads, with air regulator valve
- ✦ Spiralux Hand Riveter with Custom Machined Heads
- ✦ "Cleco" temporary fasteners and "Cleco" Pliers
- ✦ 4 Toggle Clamps and 4 Finger "Handi-Clamps"
- ✦ Drill Bits (#30, #40 and #20, supplied in recommended quantity)
- ✦ Left and Right WISS sheet-metal snips
- ✦ Adjustable ("accordian") hole spacer (10 holes)
- ✦ Metric tape measure
- ✦ Vixen "Metal Mover" 8-inch hand file
- ✦ 2 half-round 8-inch hand files
- ✦ Edge distance marker block
- ✦ Tool box
- ✦ ...and more!



Complete Tool Kit with the Sioux Air Drill:	\$ 755.00
Complete Tool Kit <i>without</i> the Air Drill:	\$ 545.00

CRATING, HANDLING & SHIPPING

Kit prices do not include any crating, handling or shipping costs. The following crating and handling charges apply for kit and component kit orders. Due to the size and weight of the kits, all kit orders are usually shipped by surface freight (truck). All shipping charges are collect (F.O.B. Factory). Call the factory for a shipping quote or additional details.

Complete Kit (Airframe + Finishing Kits together) - Domestic:	\$ 490.00
Complete Kit (Airframe + Finishing Kits together) - International:	\$ 575.00

Complete Kit Crate Size:

STOL CH 701: One Wood Crate: approximately 12' x 4' x 3', 820 lbs.

STOL CH 801: One Wood Crate: approximately 14' x 4' x 4', 1,200 lbs.

The above are crating and handling charges.

Shipping charges are additional.

Call Zenith Aircraft Company for a shipping quote or additional details.

FACTORY PICK-UP: There are no crating or shipping charges for factory pick-ups where the kit parts are loaded into your vehicle or trailer. Call for details.

Prices in U.S. funds. All shipping and freight charges collect (F.O.B. Factory). All prices, equipment and availability subject to change without prior notice. Actual contents of the Tool Kit is subject to change or revision. Recommended quantities of Clecos and drill bits are supplied.

zac: tools-ship-8-08.ai

ORDERING PROCEDURE

ORDERING PROCEDURE

To order your STOL kit, fill-in the enclosed ORDER FORM, and return to Zenith Aircraft Company with your deposit. On kit orders, a 50% deposit is required with the order. For orders totaling less than \$1,000.00, send full payment with the order. When we receive your order, a Zenith Aircraft representative will then contact you to provide you with a scheduled shipping date, and to arrange shipping or pick-up details. The balance for the order will be due prior to shipping or upon pick-up. Kit orders can be either crated and shipped to you, or picked up at the factory.

Completing the ORDER FORM:

- 1 INFORMATION ABOUT YOU:** Clearly print or type your name, mailing address and telephone numbers. If the shipping address is different than the mailing address, make sure to include both addresses.
- 2 YOUR ORDER:** Clearly itemize the kit, options and items of your order, with current pricing information.
- 3 DETAILS:** Specify any special shipping or pick-up information we need to know.
- 4 PAYMENT:** Enclose 50% deposit. Make check payable to Zenith Aircraft Company. Contact us for details on bank wire transfers or other forms of payment.
- 5 CONDITIONS of SALE and WARNING NOTICE:** Sign and validate conditions of sale and warning notice on reverse side of WHITE COPY.
- 6** Send completed WHITE copy of the Order Form with payment to Zenith Aircraft Company. Keep the YELLOW copy for your records.

When we receive your order, we will contact you to confirm receipt of your order, provide you with a scheduled delivery date, and make any required shipping / pick-up arrangements.

FACTORY PICK-UPS: Save on crating and shipping charges

When picking up a complete or component kit at the factory, the kit is not crated so that the aircraft parts can be efficiently loaded and packed on the vehicle (pick-up, van, or enclosed trailer). We recommend you bring moving blankets, corrugated cardboard, and tarps to protect the parts as you load them. Loading the kit will be your responsibility, although factory staff will be happy to lend you a hand in loading the kit. Contact Zenith Aircraft Company for more details on customer pick-ups at the factory.

NEED ADDITIONAL INFORMATION OR HELP WITH YOUR ORDER?

Contact Zenith Aircraft Company if you have any questions regarding placing your order, shipping, or other information:

Telephone: 573-581-9000 FAX: (573) 581-0011

Office Hours: Monday - Friday; 8:00 AM - 5:00 PM Central Time.

Email: info@zenithair.com

Zenith Aircraft Company has been established to service the needs of sport pilots as a Supply House for recreational aircraft hobbyists, making available aircraft designs, kits, and parts for educational purposes. Sometimes, things run into snags for reasons beyond our control. Most of them are so-called "Acts of God" like earthquakes, tornadoes, floods, fires, and the like, but some are also man-made, such as labor strikes, transportation snafus, etc. If they happen, customers get mad - and we don't blame them - but we must assign the cause where it belongs instead of being blamed for all the trouble. We earnestly hope that you won't run into any problems (most of our customers don't), but we are obligated to let you know the extent of our protecting your interest that is within our power to provide. Please read the following carefully, because if conditions listed below are not acceptable to you, you should not place this order (unless changes are made with acceptance in writing from Zenith Aircraft Co.). Your filling in this Order Form and delivering it to us constitutes your understanding and agreement of the following conditions and requirements. Thank you for your goodwill and confidence in Zenith Aircraft Company.

1. No orders are accepted by Zenith Aircraft Co., hereafter also called the Company, or Seller, unless accompanied by a payment of not less than 50-percent of the list price of all parts / kit ordered, and unless accompanied with this signed Conditions of Sale and Warning Notice. Full payment is required for the Drawings and Manuals.
2. This contract permits the buyer to build one (1) airplane (or part of it) for recreational and educational purposes only. The type of aircraft and the Drawings serial number must be visibly marked on the vertical tail or fuselage sides of the aircraft. The buyer is advised that the Drawings, Manuals, and/or parts contain proprietary rights. The buyer covenants and agrees that he will not: a) Reproduce, b) Communicate, c) Transfer, sell, exchange or modify them or any part of them, d) Permit any other person to use said drawings, manual, and/or parts, without the written permission of the Company. The sole purpose of the plans, drawings, manuals, and parts is strictly educational and there is no implied or expressed warranty. During the construction the buyer is to cause the structure and installations to be inspected and approved by the relevant government and/or aviation authority (FAA) prior to registration in the Custom-Built, Experimental, Ultralight, etc. category. The Buyer agrees to notify the Company in writing immediately of the sale of any Drawings and Manuals, parts, components, or kit, whether completed or not, supplying the complete name and address of the new owner(s).
3. The Company will not be held responsible for any delays in deliveries due to delays of carriers, fires, and other Acts of God, or other causes for delay beyond its control.
4. Claims for defective materials or missing parts will be allowed only when such claims are made within thirty (30) days from the date of delivery. No goods may be returned unless previously authorized by the Company. (Inspect your order for missing or damaged parts immediately upon receipt).
5. Orders accepted by the Company may be canceled by the buyer within fifteen days of the date of order without the company's advance approval, provided: a 10-percent cancellation charge is assessed if goods were not yet shipped, or a 20-percent charge if the goods were shipped and are returned. Any delivered order not picked-up or accepted by the buyer for more than thirty days shall be considered to be forfeited. Drawings and Manuals, or other printed materials, may not be returned for credit or refund. PROVIDED HOWEVER, in no event will seller accept goods for return for any reason the earlier of thirty days (30) days from the date of shipment, or assembly, installation, construction, or modification of any product, whichever occurs first.
6. Unless otherwise specified, the buyer agrees to pay in full for, and take delivery of, the merchandise in not more than two weeks after receiving notification that it is ready for shipment. Storage rental shall be charged beyond that time. It is the sole responsibility of the buyer to pay any applicable sales tax or usage tax, in whichever state(s), and all applicable shipping and shipping related charges.
7. All orders not delivered for lack of shipping instructions, payments, or any other delays caused by the buyer for longer than thirty days shall be considered forfeited and void, and the Company will have the right to scrap or dispose of the merchandise at its discretion and retain the full deposit.
8. All prices are F.O.B. Factory and subject to change without notice. Delivery to the Carrier shall constitute the delivery to the buyer, and the responsibility for the goods in transit shall be the Carrier's and the buyer's. A Bill of Lading (or Way-Bill) shall be sufficient evidence and proof of the date of shipment. Claims of damage in transit shall be made to the Carrier and not the Company. NOTICE: If any container or crate shows the slightest damage on delivery, it should be opened and inspected before acceptance from the Carrier, and a statement of damage made immediately. Insurance of goods in transit is the responsibility of the buyer, and the Company will not pay for goods damaged in transit, nor for shipping charges to and from the factory of returned shipments, damaged, or replacement parts.
9. This contract shall be governed by and construed in accordance with the laws of the State of Missouri, and is the only contract controlling this sale and purchase, and it contains all the agreements, expressed or implied, either verbal or in writing, made between the Company and the buyer. If any provisions of this contract shall be held to be invalid, the remaining provisions shall continue to be valid. This Agreement and the covenants, promises and agreements contained herein shall be governed in accordance with the laws of the state of Missouri, United States. This Agreement shall be deemed executed and delivered in Missouri. The parties consent to the venue of any state court sitting in Audrain County, Missouri, United States, or the United States District Court, Eastern District of Missouri, in any action brought to enforce the terms of this Agreement. The parties irrevocably and unconditionally submit to the jurisdiction (both subject matter and personal) of any such court and irrevocably and unconditionally waive: (i) any objection any party might now or hereafter have to the venue in any such court; and (ii) any claim that any action or proceeding brought in any such court has been brought in an inconvenient forum. The parties acknowledge that the United Nations Convention on Contracts for the International Sale of Goods shall not apply to this Agreement.
10. Custom-built aircraft are licensed by the government to fly in the applicable "Experimental," "Amateur-Built" or "Ultralight," etc. category. Each aircraft is treated legally by the governing authority (FAA) as a "one-of-a-kind" in design and construction, and is liable to be unpredictable, hazardous, and even potentially lethal. Therefore, construction and operation of such aircraft may be unsafe without acquiring, studying and complying to the letter of all instructions and manuals pertaining thereto. The Seller does not warrant that the aircraft as constructed by the buyer, or any other person, will be airworthy, or will qualify for certification or registration by aviation authorities, or will meet the requirement of the buyer. Notwithstanding the forgoing, seller may provide from time to time, but is not required to provide, technical assistance during the assembly, installation and construction process. However, buyer and seller specifically agree that responsibility for building the aircraft or its parts shall rest solely with the buyer and that no liability shall arise from or extend from any technical assistance provided by seller. Purchaser acknowledges that the assembly and construction of the product requires certain technical experience and skill. Further seller and purchaser specifically agree that the seller cannot and does not warrant the ability of any individual, including purchaser, to properly assemble, construct and maintain an aircraft kit of the kind sold by seller. In exchange for such technical assistance, purchaser and seller specifically agree that purchaser shall hold harmless seller from any and all liability which may arise from any technical advice provided by seller, seller's employee, or seller's agent.

11. EXCLUSIONS OF WARRANTIES, NO WARRANTIES. THE IMPLIED WARRANTIES OF MERCHANTABILITY AND FITNESS FOR A PARTICULAR PURPOSE AND ALL OTHER WARRANTIES, EXPRESS OR IMPLIED, ARE EXCLUDED FROM THIS TRANSACTION AND SHALL NOT APPLY TO THE GOODS SOLD, THE CONSTRUCTION OF THE GOODS, THE PLANS & MANUALS, THE GOODS WORKMANSHIP, THE SAFETY OF THE GOODS DESIGN OR ANY OF THE GOODS COMPONENTS.

12. In recognition of the above, and because they cannot control nor assure quality and accuracy of compliance with their instructions during and after construction of such aircraft, the Seller and/or Owner (and their agents, servants, employees, contractors, successors and assigns) hereby give notice to the Buyers and/or Operators (and their heirs, administrators and assigns) of this aircraft, that they carry no liability insurance.

13. BY SIGNING THIS DOCUMENT, AND BY PROCEEDING WITH THIS ORDER, THE BUYER ATTESTS THAT HE HAS THE FULL AUTHORITY AND CAPACITY TO SIGN AND VALIDATE THIS DOCUMENT. THE BUYER(S) AND/OR OPERATOR(S), AS DEFINED ABOVE, ACKNOWLEDGE THE RECEIPT AND UNDERSTANDING OF THIS WARNING NOTICE AND SO SIGNIFY, BY THEIR DECISION TO GO AHEAD WITH PURCHASING, ACCEPTING AND OPERATING THIS AIRCRAFT, OR ANY OF ITS PARTS, AND AGREE TO HOLD THE SELLER AND/OR OWNER, AS DEFINED ABOVE, HARMLESS FROM ALL LIABILITY AND FROM ANY CLAIMS OF DAMAGES AND CAUSES OF ACTION WHICH MAY BE INCURRED BY THEM OR ANY THIRD PARTY AS A RESULT OF THE PURCHASE, USE, CONSTRUCTION, AND OPERATION OF THIS AIRCRAFT, ITS PLANS, PARTS AND COMPONENTS. BUYER AND/OR OPERATOR HEREBY ASSUME ALL RISK, LIABILITY AND RESPONSIBILITY RELATIVE TO THE CONSTRUCTION AND OPERATION OF THE AIRCRAFT.

BUYER'S NAME:

SIGNATURE:

ADDRESS:

DATE:

TELEPHONE:

SPOUSE / NEXT OF KIN SIGNATURE:

If more than one buyer, each buyer must sign this form.