

STOL CH 701 SPORT UTILITY KIT AIRCRAFT

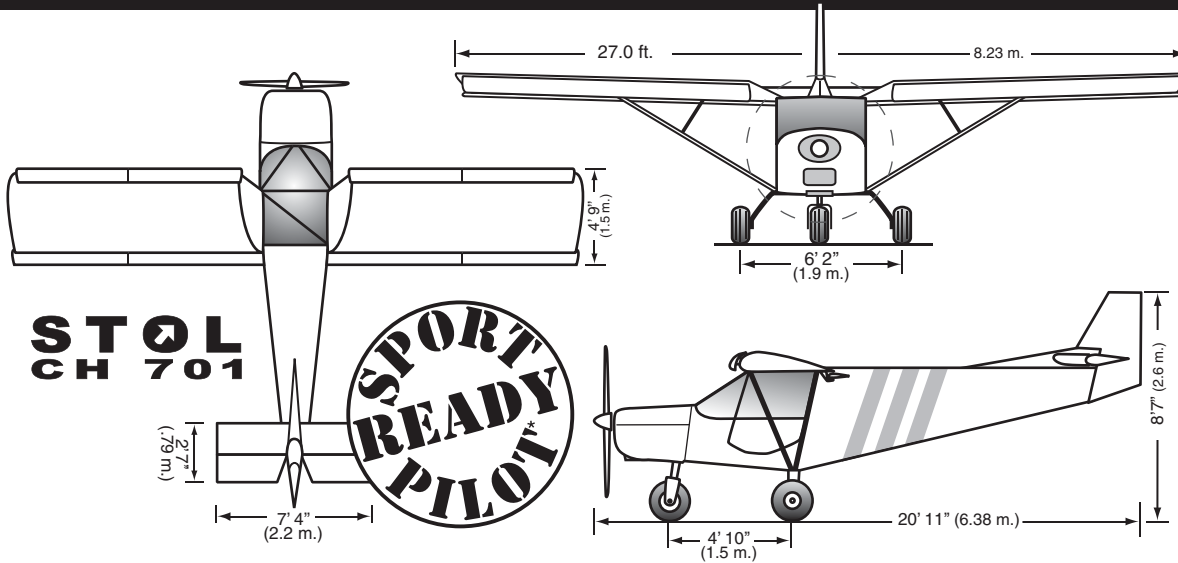

**Two Seats
STOL Performance!**

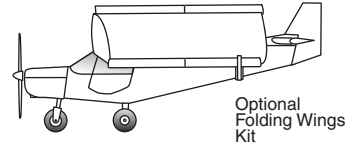
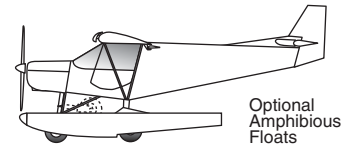

**"Simple to Build,
Fun to Fly"**
- KITPLANES magazine

PERFORMANCE & SPECIFICATIONS

PERFORMANCE with Rotax 912 ULS - 100 hp	Single	Dual	SPECIFICATION FIGURES		
			Standard Configuration		
TAKE-OFF ROLL	60 Feet	90 Feet	LENGTH	20 Ft. 11 In.	6.38 m.
TOP SPEED	95 MPH	95 MPH	HEIGHT	8 Ft. 7 In.	2.6 m.
CRUISE SPEED (75%)	85 MPH	85 MPH	WING SPAN	27 Ft. 0 In.	8.23 m.
STALL SPEED	28 MPH	30 MPH	WING AREA	122 Sq. Ft.	11.4 m.sq.
RATE OF CLIMB	1,600 fpm	1,400 fpm	EMPTY WEIGHT	580 Lbs.	263 kg.
SERVICE CEILING	16000+ Ft.	14000+ Ft.	GROSS WEIGHT	1,100 Lbs.	500 kg.
RANGE (no reserve)	350 miles	350 miles	USEFUL LOAD	520 Lbs.	236 kg.

Above performance and specification figures with the Rotax 912 ULS engine (100 BHP). Standard atmosphere, sea level, no wind. Performance and specification figures based on prototype flight test results; subject to change without notice. Different engines and options will affect performance and specification figures. * Subject to meeting actual FAA rules.

STOL CH 701 Complete Kit: Airframe Kit + Finishing Kit

The STOL CH 701 airframe kit comes with all kit parts to build the airframe: The kit includes the factory riveted wing spars, pre-formed sheet-metal parts (ribs, skins, etc.), factory-welded parts, standard fuel system (welded aluminum wing tanks), controls, and hardware required for assembly of the airframe. Most skins are now supplied CNC pre-cut and pre-drilled! The kit includes the Drawings and Manuals.

The Finishing Kit includes the items to complete the aircraft, including the All-Terrain Gear and wheels with hydraulic disk brakes, the formed plexiglass windshield, swing-up doors, seat belts, wing struts, hardware, and more.

Not included: firewall-forward powerplant and instruments packages, paint, and upholstery.

*The Original
"Sky Jeep"*

STOL CH 701 Airframe Kit

\$ 10,795.00

STOL CH 701 Finishing Kit

\$ 3,195.00

Powerplant Packages

'Firewall-forward' powerplant packages are available for the the Rotax 912 series engine and select other engines. Complete firewall-forward packages include all accessories for installation: engine mount, vibration dampeners, generator, voltage regulator, exhaust and intake manifolds, 'easy-access' fiberglass engine cowl, cooling system, carburetors, propeller, engine controls, hardware and installation and operating manuals. Battery and wiring not included. Instruments (avionics) packages are also available and are very customizable. Complete Garmin and Dynon systems are available, ready in install. Contact us for current pricing info and to discuss specific options. Included equipment subject to change.

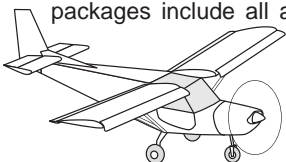

Available Options: Bubble Doors, Electric Trim, LED Nav/Strobe Lights, Folding Wings Kit, Auxiliary Wing Tanks, and more.

Sport Pilot Ready: *Subject to meeting FAA rules as constructed by the builder. Zenith Aircraft Company cannot guarantee that the kit aircraft, as constructed by the builder, will meet the definition of a Light-Sport Aircraft.

ZENITH AIRCRAFT CO.
PO Box 650, Mexico Memorial Airport,
Mexico, Missouri 65265-0650 USA
TEL: 573-581-9000 FAX: 573-581-0011



Facebook.com/zenithair

Visit us online for complete details
zenithair.com

Prices in US Funds. Prices and availability subject to change without notice.
Prices are F.O.B. Factory. Crating and shipping charges are extra.

STOL CH 701 SPORT UTILITY KIT AIRCRAFT

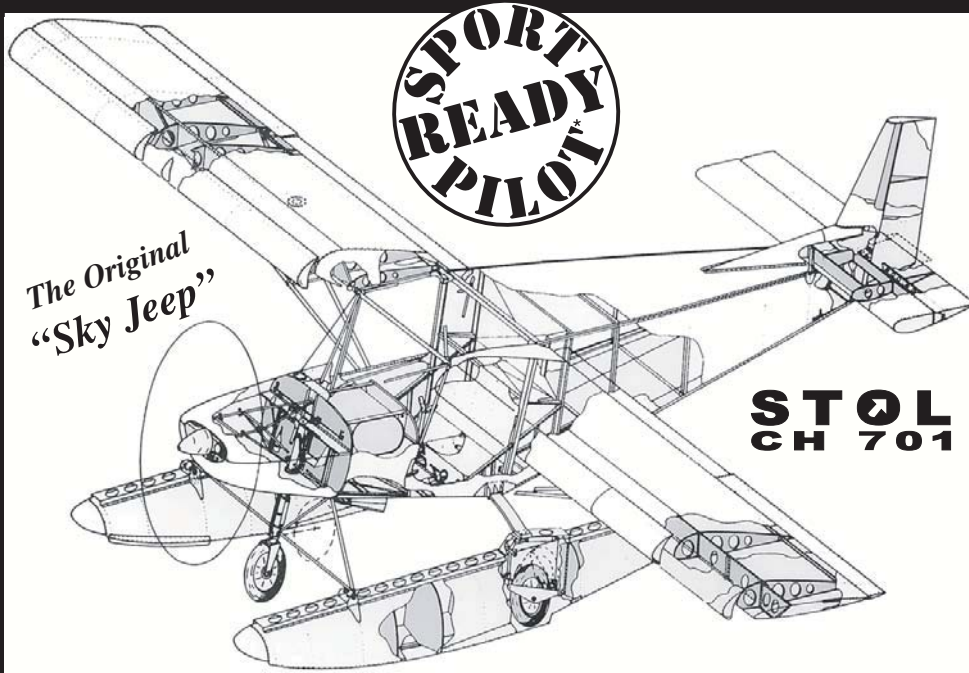

**Popular since 1986.
Celebrating over 30 years
of fantastic STOL flying!**

While the basic design has remained the same, many significant improvements have been introduced over the years to the STOL CH 701, including a higher useful load, easier and quicker to build kits, and more detailed drawings and assembly instructions.

**“Simple to Build,
Fun to Fly”**

New Kit Features – Easier to Build

The standard STOL CH 701 kit now includes many CNC pre-cut and pre-drilled skins and components, and is now available as a complete package with your choice of engine.



Build your own STOL CH 701 kit aircraft from:

- ★ **Complete Kit:** *Everything you need in One Box.*
- ★ **Component Buy-As-You-Build Kits**
- ★ **Plans-Only:** *New CAD Blueprints and Manuals allow you to scratch build the aircraft. Parts and components are available individually.*
- ★ **Professional Builder Assist Centers** *for help building your own.*

Design Features:

- ★ PROFESSIONAL, PROVEN DESIGN
First flown in 1986 with hundreds flying
- ★ DURABLE ALL-METAL CONSTRUCTION
- ★ FULL LENGTH FLAPERONS (AILERONS & FLAPS)
- ★ FULLY STEERABLE NOSEWHEEL
- ★ RUGGED ALL-TERRAIN GEAR & WHEELS
- ★ LARGE WHEELS WITH 16-INCH ‘TUNDRA’ TIRES
- ★ HYDRAULIC DISK BRAKES
- ★ REMOVABLE WINGS (Folding Wing Option also available)
- ★ OPTIONAL CLEAR ACRYLIC “BUBBLE DOORS”
- ★ ALL-FLYING RUDDER
- ★ MANY ENGINE TYPES CAN BE CUSTOM INSTALLED

Cabin Area:

- ★ ROOMY SIDE-BY-SIDE SEATING
- ★ 44-INCH WIDE CABIN WITH THE BUBBLE DOORS
- ★ EXTENDED BAGGAGE COMPARTMENT (REAR OF SEATS)
- ★ OUTSTANDING VISIBILITY
- ★ EASY CABIN ACCESS FROM EITHER SIDE
- ★ “SWING-UP” LOCKING DOORS
- ★ **Engine Choices:**
 - ★ **100-hp ROTAX 912 ULS**
 - ★ **Auto conversions, and more**
- ★ **FIREWALL FORWARD INSTALLATION PACKAGES AVAILABLE**

Prices, equipment, features and availability subject to change without notice. 701sp-7-2018-p2.ai

STANDARD KIT EQUIPMENT:

- ★ MANY PRE-DRILLED SKINS AND PRE-CUT ON THE CNC ROUTER!
Most flat fuselage and wing skins are supplied pre-drilled from the factory.
- ★ LOW KIT BUILD TIME:
Less than 500 hours
- ★ WELDED ALUMINUM FUEL TANKS:
Kit includes all basic fuel system plumbing, including gascolator and fuel level senders and gauges.
- ★ FACTORY-RIVETED WING SPARS AND LOWER CABIN FRAME SIDES
- ★ FORMED FIBERGLASS TIPS:
Wings, flaperons, slats tips.
- ★ LANDING GEAR SYSTEM: Kit includes wheels, tires, and hydraulic brakes.
- ★ ACRYLIC (PLEXIGLASS) FORMED WINDSHIELD
- ★ SIMPLE BUILDING TECHNIQUE (BASIC SKILLS AND TOOLS)
- ★ MODULAR CONSTRUCTION MINIMIZES WORKSHOP SPACE REQUIREMENTS
- ★ NO MESSY & HAZARDOUS DOPING OR COMPOSITE WORK
- ★ TECHNICAL SUPPORT DIRECTLY FROM THE FACTORY.